

This drawing contains proprietary information owned or controlled by RPVisual Solutions and must not be used or disclosed without prior written authorization

DIMENSIONS ARE IN INCHES  
TOLERANCES ARE:  
FRACTIONS: X/X : ± 1/32  
DECIMALS: .XX : ± .03  
          .XXX : ± .010  
ANGLES: X : ± .5  
          .XX : ± .20

**APPROVED FOR FABRICATION**

SIGNATURE: \_\_\_\_\_

DATE: \_\_\_\_\_

NOTES:

1. FINISH: SEMI-GLOSS BLACK POWDER COAT
2. TOTAL WEIGHT (APPROXIMATE): 70 LBS

G			
F			
E			
C			
B			
A	CONDUIT SPACE FROM 15.78" TO 15.18"	GS	9/8/2023
REV:	DESCRIPTION:	BY:	DATE:
DEALER:			

PROJECT: \_\_\_\_\_

SKU: RPWM-32BF-XMS-UNV

PART NO: 0002-300-00

DESCRIPTION: UNIVERSAL MOUNT - PULL OUT WALLMATE 32BF KIT

SIZE: B	DATE: 9/12/2023	DRAWN: GS	CHECKED: XX
---------	-----------------	-----------	-------------

DWG. ID: RPWM-32BF-XMS-UNV.1

JOB NO:	SCALE: 1:8	REVISION: A
	SHEET: 1 OF 4	

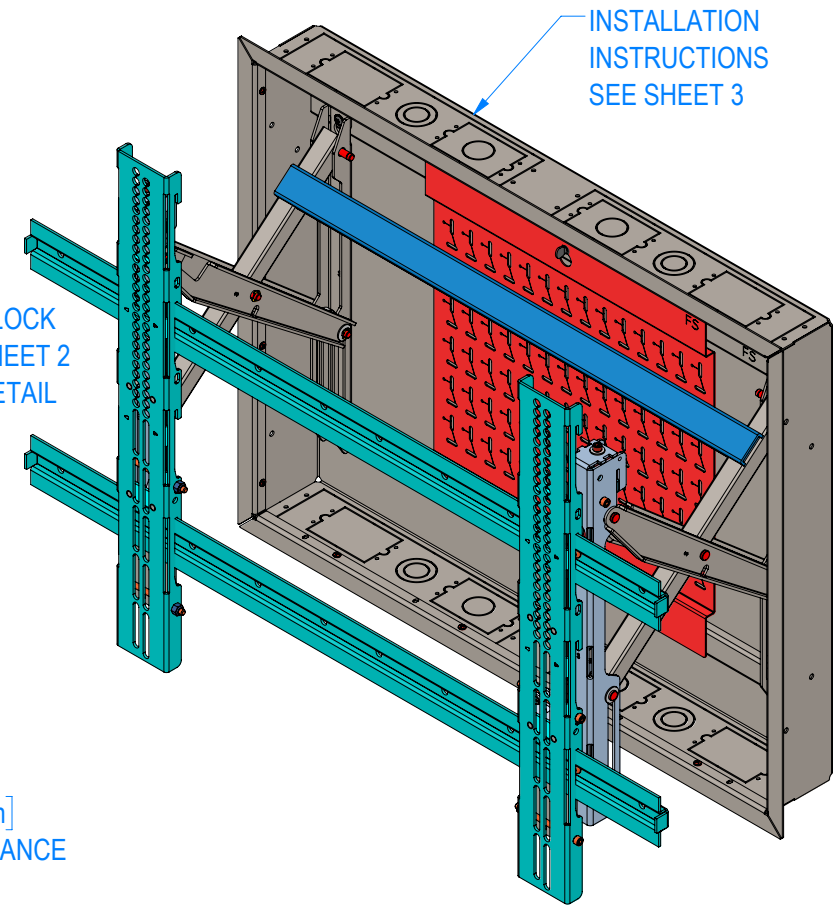

INSTALLATION INSTRUCTIONS SEE SHEET 3

OPEN LOCK SEE SHEET 2 FOR DETAIL

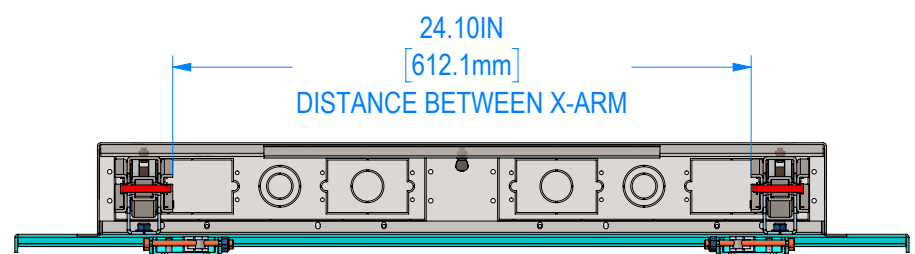

24.10IN [612.1mm]  
DISTANCE BETWEEN X-ARM

SECTION B-B

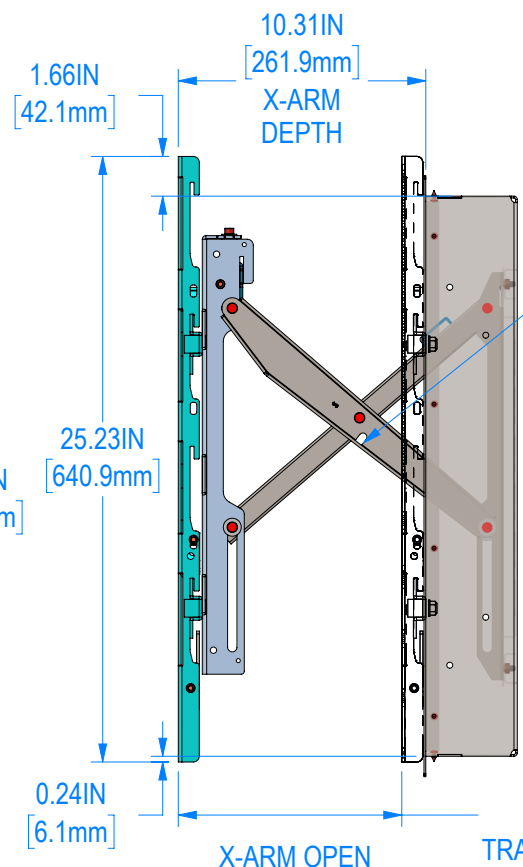

10.31IN [261.9mm]  
X-ARM DEPTH

X-ARM OPEN

TRAVEL DISTANCE

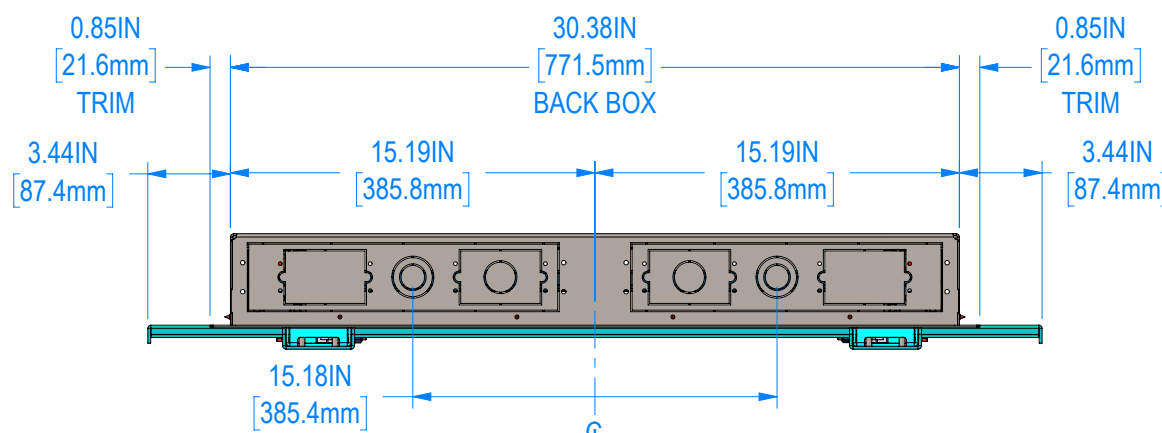

TOP VIEW

0.85IN [21.6mm] TRIM  
30.38IN [771.5mm] BACK BOX  
0.85IN [21.6mm] TRIM  
3.44IN [87.4mm]  
15.19IN [385.8mm]  
15.19IN [385.8mm]  
3.44IN [87.4mm]  
15.18IN [385.4mm]

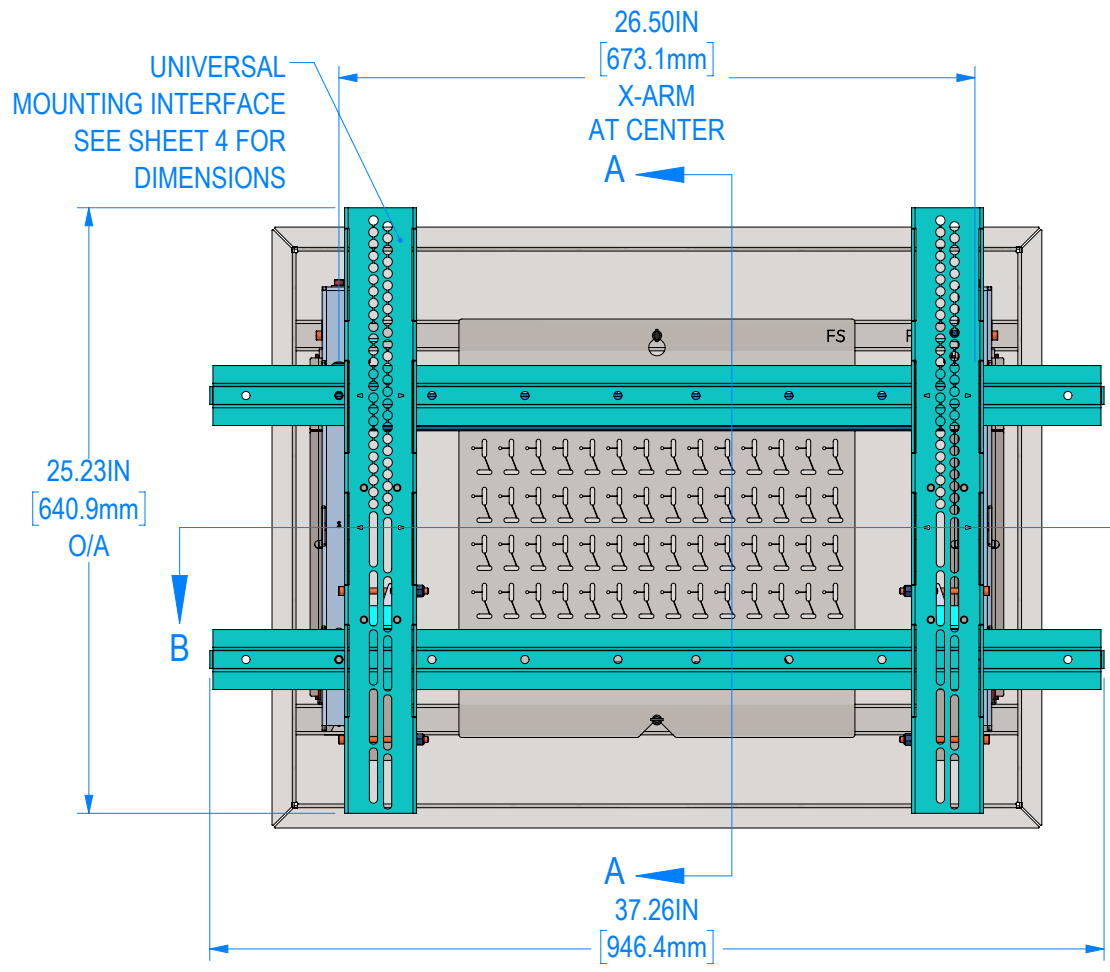

FRONT VIEW

UNIVERSAL MOUNTING INTERFACE SEE SHEET 4 FOR DIMENSIONS  
26.50IN [673.1mm] X-ARM AT CENTER  
A  
25.23IN [640.9mm] O/A  
B  
37.26IN [946.4mm] O/A

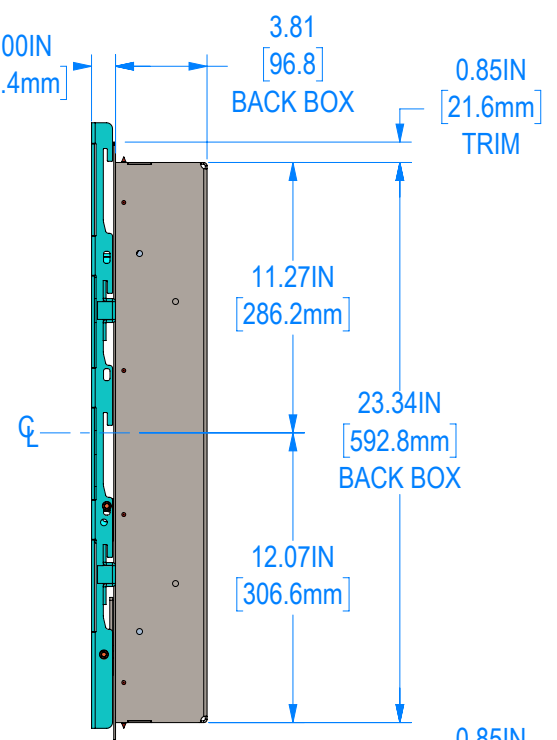

SIDE VIEW

1.00IN [25.4mm]  
3.81 [96.8] BACK BOX  
0.85IN [21.6mm] TRIM  
11.27IN [286.2mm]  
23.34IN [592.8mm] BACK BOX  
12.07IN [306.6mm]  
0.85IN [21.6mm] TRIM

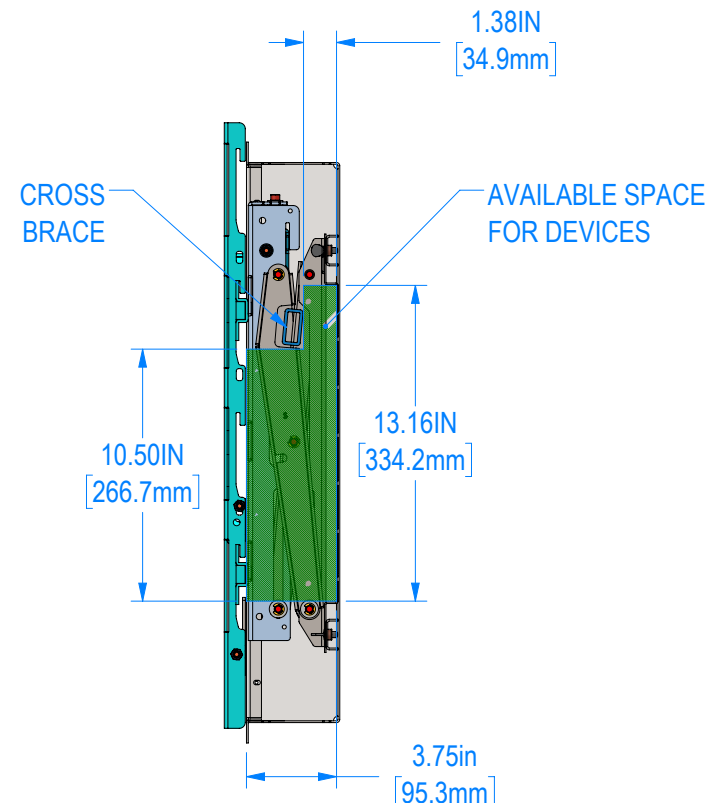

SECTION A-A

1.38IN [34.9mm]  
CROSS BRACE  
AVAILABLE SPACE FOR DEVICES  
10.50IN [266.7mm]  
13.16IN [334.2mm]  
3.75in [95.3mm]

This drawing contains proprietary information owned or controlled by RPVisual Solutions and must not be used or disclosed without prior written authorization

*DIMENSIONS ARE IN INCHES*

*TOLERANCES ARE:*

FRACTIONS	DECIMALS	ANGLES
X/X : ± 1/32	.XX : ± .03	.X : ± .5
	.XXX : ± .010	.XX : ± .20

**APPROVED FOR FABRICATION**

SIGNATURE: \_\_\_\_\_

DATE: \_\_\_\_\_

NOTES:

G			
F			
E			
C			
B			
A			

REV: DESCRIPTION: BY: DATE:

DEALER:

PROJECT:

SKU: RPWM-32BF-XMS-UNV

PART NO: 0002-300-00

DESCRIPTION: UNIVERSAL MOUNT - PULL OUT WALLMATE 32BF KIT

SIZE: B	DATE: 9/12/2023	DRAWN: GS	CHECKED: XX
---------	-----------------	-----------	-------------

DWG. ID: RPWM-32BF-XMS-UNV.2

JOB NO:	SCALE: 1:5	REVISION: A
	SHEET: 2 OF 4	

Ø 0.63IN  
[15.9mm]  
KEYHOLE X2,  
UPPER X-ARM

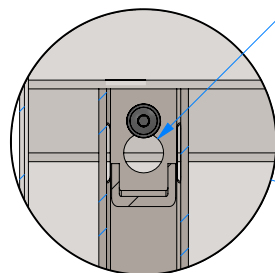

DETAIL D  
SCALE 1:3

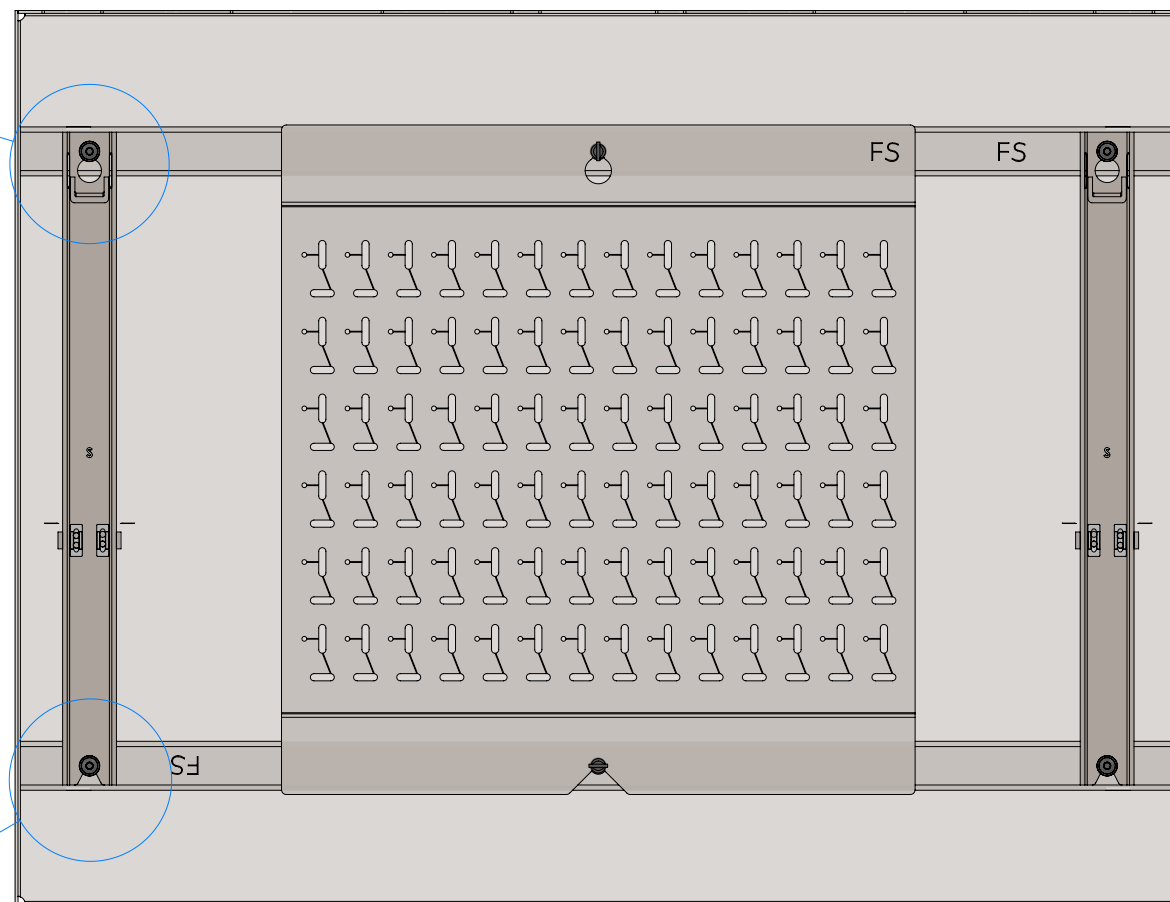

SECTION C-C

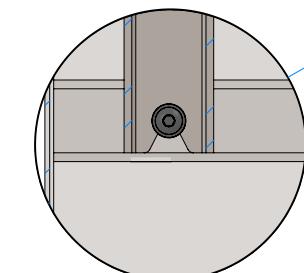

DETAIL E  
SCALE 1:3

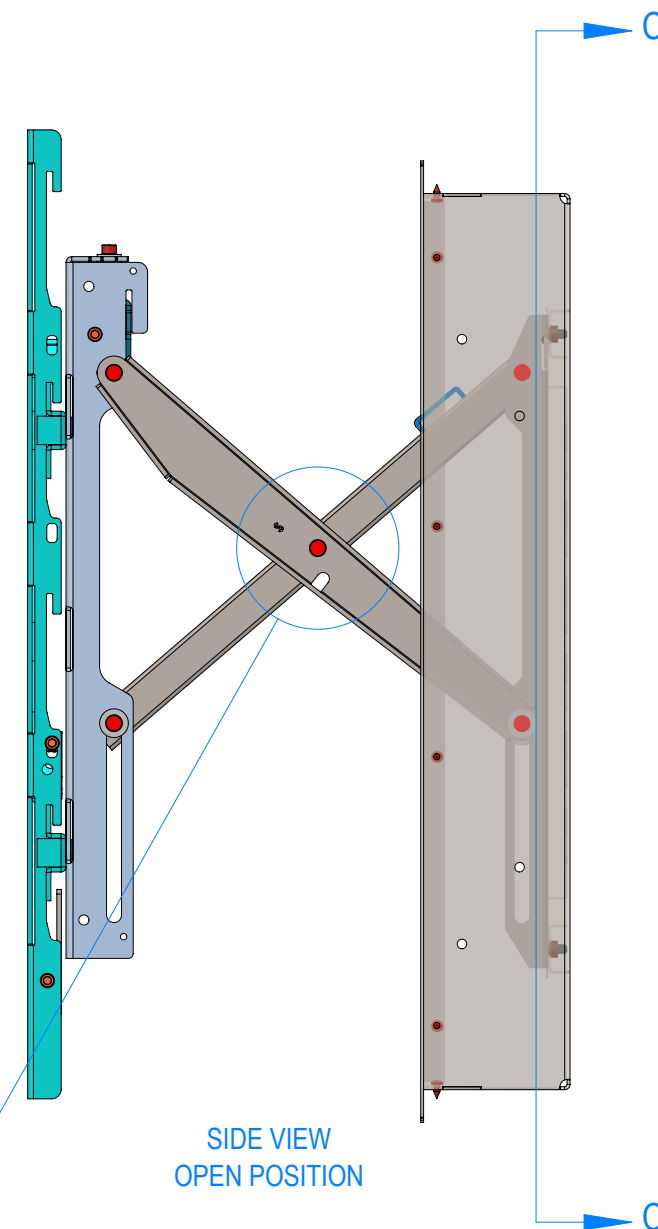

SIDE VIEW  
OPEN POSITION

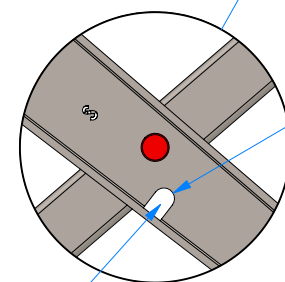

DETAIL F  
SCALE 1:3

USE THIS LOCATION  
TO LOCK X-ARM  
IN OPEN POSITION

Ø 0.33IN  
[8.4mm]

This drawing contains proprietary information owned or controlled by RPVisual Solutions and must not be used or disclosed without prior written authorization

DIMENSIONS ARE IN INCHES

TOLERANCES ARE:

FRACTIONS	DECIMALS	ANGLES
X/X : ± 1/32	.XX : ± .03 .XXX : ± .010	.X : ± .5 .XX : ± .20

**APPROVED FOR FABRICATION**

SIGNATURE: \_\_\_\_\_

DATE: \_\_\_\_\_

**NOTES:**

1. FINISH: SEMI-GLOSS BLACK POWDER COAT
2. TOTAL WEIGHT (APPROXIMATE): 70 LBS

G			
F			
E			
C			
B			
A			

REV: DESCRIPTION: \_\_\_\_\_ BY: \_\_\_\_\_ DATE: \_\_\_\_\_

DEALER: \_\_\_\_\_

PROJECT: \_\_\_\_\_

SKU: RPWM-32BF-XMS-UNV

PART NO: 0002-300-00

DESCRIPTION: UNIVERSAL MOUNT - PULL OUT WALLMATE 32BF KIT

SIZE: B	DATE: 9/12/2023	DRAWN: GS	CHECKED: XX
---------	-----------------	-----------	-------------

DWG. ID: RPWM-32BF-XMS-UNV.3

JOB NO:	SCALE: 1:8	REVISION: A
	SHEET: 3 OF 4	

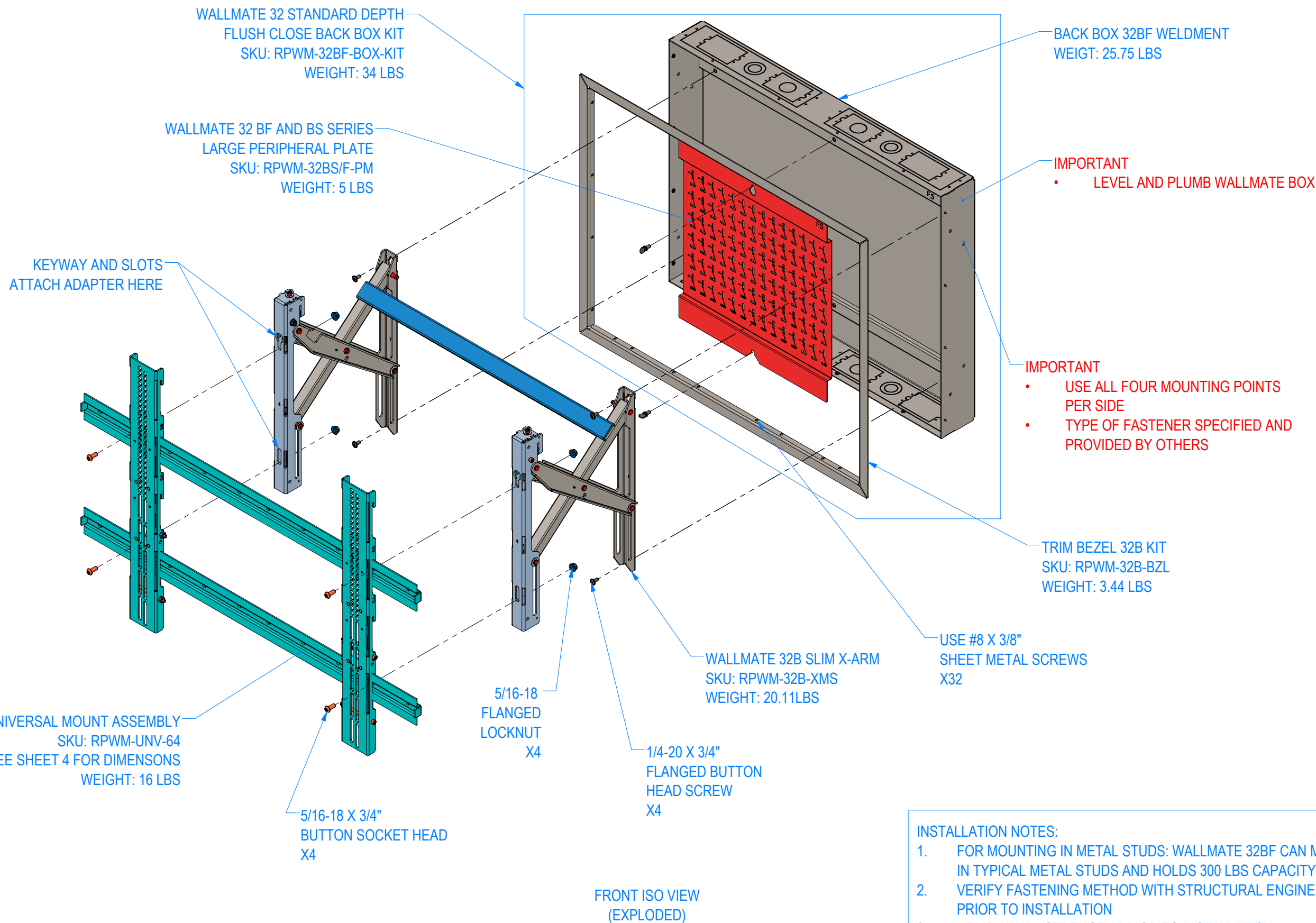

- INSTALLATION NOTES:**
1. FOR MOUNTING IN METAL STUDS: WALLMATE 32BF CAN MOUNT IN TYPICAL METAL STUDS AND HOLDS 300 LBS CAPACITY
  2. VERIFY FASTENING METHOD WITH STRUCTURAL ENGINEER PRIOR TO INSTALLATION
  3. VERIFY WALL STRENGTH PRIOR TO INSTALLATION
  4. USE ALL FASTENING POINTS ON BOTH SIDES OF BOX

**NOTE TO CONTRACTOR:**  
 USE SUPPLIED HARDWARE WITH CAUTION:  
 - SCREWS CAN EXCEED DISPLAY INSERT LENGTH  
 - VERIFY INSERT LENGTH WITH DISPLAY  
 MANUFACTURER PRIOR TO USE

**DISPLAY MOUNTING HARDWARE PROVIDED BY RPV:**  
 QTY: 4 / UNIT - M6 X 16mm FLANGED SBHCS ALLOY  
 QTY: 4 / UNIT - M8 X 16mm, M8 X 20mm FLANGED SBHCS ALLOY  
 QTY: 4 / UNIT - M8 X 40mm SBHCS ALLOY  
 QTY: 4 / UNIT - 5/16" ID X 3/4" OD FLAT WASHER

This drawing contains proprietary information owned or controlled by RPVisual Solutions and must not be used or disclosed without prior written authorization

DIMENSIONS ARE IN INCHES  
 TOLERANCES ARE:  
 FRACTIONS DECIMALS ANGLES  
 X/X : ± 1/32 .XX : ± .03 .X : ± .5  
 .XXX : ± .010 .XX : ± .20

**APPROVED FOR FABRICATION**

SIGNATURE:

DATE:

NOTES:

1. FINISH: SEMI-GLOSS BLACK POWDER COAT
2. TOTAL WEIGHT (APPROXIMATE): 16 LBS

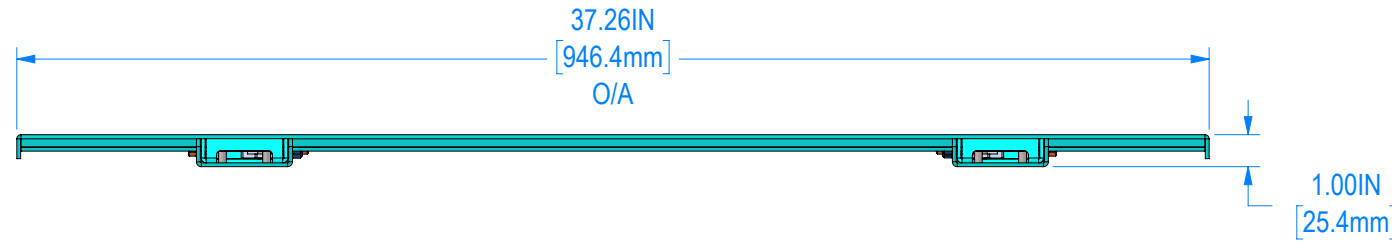

FRONT VIEW

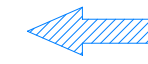

DISPLAY THIS SIDE

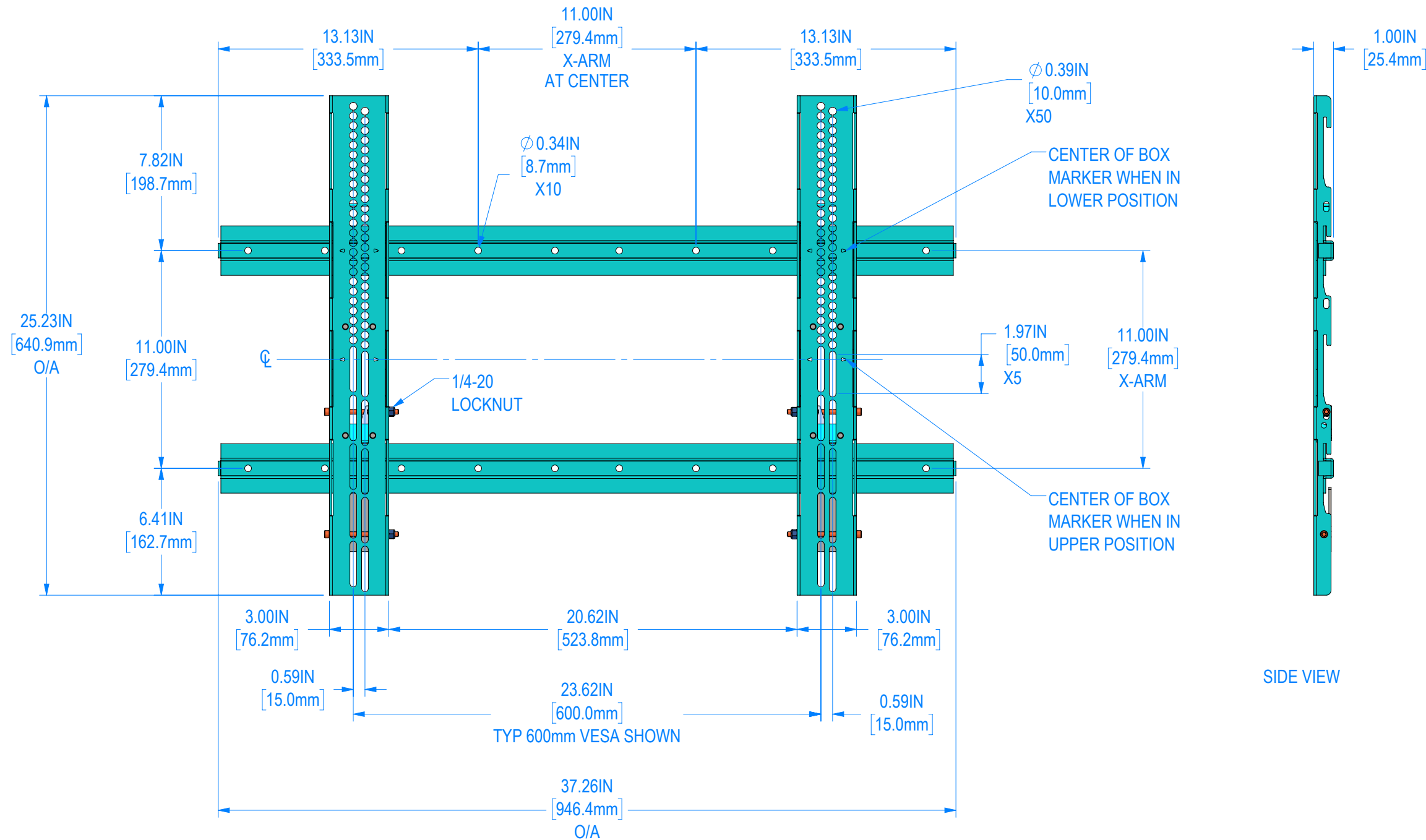

FRONT VIEW

SIDE VIEW

G			
F			
E			
C			
B			
A			

REV: DESCRIPTION: BY: DATE:

DEALER:

PROJECT:

SKU: RPWM-UNV-64

PART NO: 0006-000-00F

DESCRIPTION: UNIVERESAL MOUNT ASSEMBLY

SIZE: B DATE: 9/12/2023 DRAWN: GS CHECKED: XX

DWG. ID: RPWM-32BF-XMS-UNV.4

JOB NO: SCALE: 1:6 SHEET: 4 OF 4 REVISION: F