

WALLMATE Tile Based LED

Tile Based Flat Panel Mounting System

FOR DISPLAYS UP TO 700 LBS*¹⁰

The Wallmate LED-T series is designed to hold tile LED displays from 81" up to 138", while enabling easy service access.⁴

- X-arm has been redesigned to enable close as low as 0.6".
- Manufactured with 11 to 14-gauge plate and tube steel as well as machined services to create a rigid mount that will remain stable and level.
- Installation only requires simple tools such as a drill, screwdriver, and Allen key.

Peripheral storage space makes it easy to mount AV gear behind the display while still remaining flush against the wall.

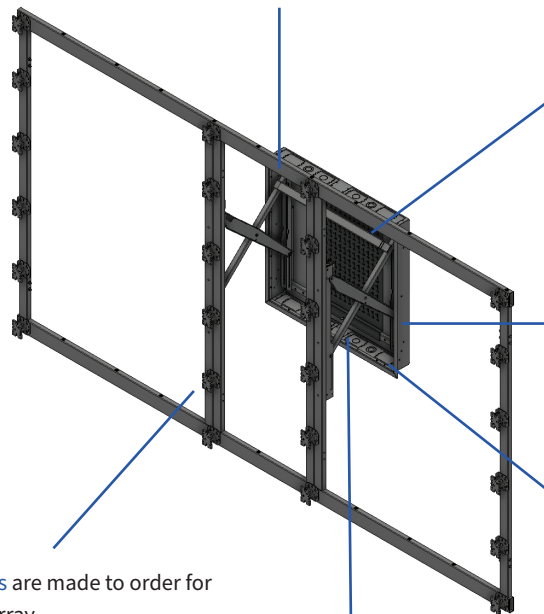

Mounting interfaces are made to order for up to 5x5 LED tile array.

Rapid deployment quick-remove peripheral plates enable faster and more reliable roll outs by facilitating AV equipment being pre-dressed, and pre-tested.

B6 back box has been designed from the ground up to support heavy weight loads.

Includes electrical knock outs for conduit and single gang boxes.

New Unique proprietary roller X-arm allows exceptionally smooth and easy operation under high weight loads.

Wallmate 32MAXB6-XMR-LED-T Product Specifications

Structure in Wall	Cannot be stud mounted. Requires in wall structure by RPV or structural team.
Min. Landscape and Portrait Panel Size	81"
Max Recommended Display Size Dia. 16:9	138"
Max Display Size Dia. 21:9	126"
Max Display Thickness to Hit ADA - Non Shift	3.0" including interface ²
X-arm Opening Distance (wall to back of display)	15.44" ⁹
X-arm Closed Distance (wall to back of display)	TBD
X-arm Plumb Alignment	-0.62° to 0°
Display Weight Capacity	700 lbs.
Approx. Display Weight Capacity ⁵ / X-arm Max Load	700 / 820
Internal Mount Space X-arm (WxHxD)	23.75" x 19.34" x 4.16"
Peripheral Plate Dim (WxHxD inches)	17.5" x 26.75" x 0.5"
Box External Dimensions - No Trim (WxHxD)	30.38" x 30.38" x 3.81"

Box & Trim External Dimensions (WxHxD)	32.1" x 32.1" x 3.81"
Plate Attach Pattern to X-arm (WxH)	26.5" x 11" x 11"
1-Gang Box Positions (top and bottom)	4 each
Conduit Knock Outs (top)	4 (qty. 2 x 1", qty. 2 x combo 0.75"/1.25")
Conduit Knock Outs (bottom)	4 (qty. 2 x 1", qty. 2 x combo 0.75"/1.25")
AUX Tray Position	2
1" Metal Multi-Piece Trim	Included with back box
System Weight	300 lbs.* ⁸

Wallmate 32MAXB6-XMR-LED-T Model Numbers

Wallmate RPWM-32MAXB6-XMR-LED-T Kit with Tile Based LED Mounting Plate (as shown in images)

Part Number	Description	Typical Purchaser
RPWM-32MAXB6-XMR-LED-T	Wallmate 32MAXB6 System for tile based LED systems up to 137" diagonal. Includes B6 back box, peripheral plate, box trim bezel, heavy duty roller x-arm, and made to order LED tile mounting frame, up to 5x5 tile array. Box and x-arm can hold 820 lbs. Estimated display weight 700 lbs.	Integrator
RPWM-32MAXB6-BOX-KIT	Metal back box for Wallmate 32MAXB6 systems. Mounts in 3.5" depth. Includes black peripheral plate and black trim bezel. Integrated XMR heavy duty x-arm mounting points, 8 single gang box knock outs, 4 multi size conduit knock outs, 4 1" conduit knock outs, 2 knock outs for bottom auxiliary tray. Refer to structural engineer for wall build out. Gray box color. Up to 820 lbs. (372.7kg) on x-arm. X-arm and interface sold separately.	General or electrical contractors (Split scope part 1 of 2)
RPWM-32MAXB6-XMR-LED-T-NB	Wallmate 32MAXB6 system for tile based LED systems up to 137" diagonal. Includes heavy duty roller x-arm, and made to order LED tile mounting frame, based on 5x5 tile array. Back box kit sold separately. Box and x-arm can hold 820 lbs. Estimated display weight 700 lbs.	Integrator (Split scope part 2 of 2)

Additional Wallmate 32MAXB6 Accessories and Kits

Part Number	Description
RPWM-32MAXB6-HFRAME	Wallmate 32MAXB6 in wall H-frame
RPWM-32MAXB6-PM	Peripheral device mounting plate for Wallmate 32MAXB6
RPWM-32MAXB6-PM2	Dual layer peripheral device mounting plate for Wallmate 32MAXB6
RPWM-32MAXB-BZL#	Wallmate 32MAXB deep trim
RPWM-32MAXB-CVR	Blank back box cover plate for Wallmate 32MAXB
RPWM-LOCK-R	Wallmate B6 XMR x-arm lock Kit
RPWM-TOUCH-R	Wallmate B6 XMR x-arm touch kit
RPWM-EUPWR	European power adapter plate
RPWM-UC-LT-KCAM	Camera/Bar mounting kit for Wallmate LED tiles systems
Kits	Description
RPWM-32MAXB6-XMR-LED-A	Made to order All-in-one LED Wallmate mounting system up to 137" dia.

FRONT VIEW

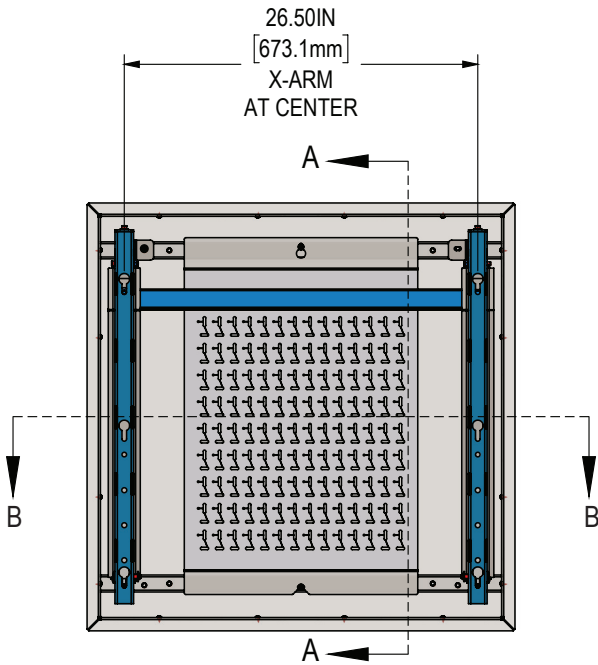

SIDE VIEW (X-ARMS OPEN)

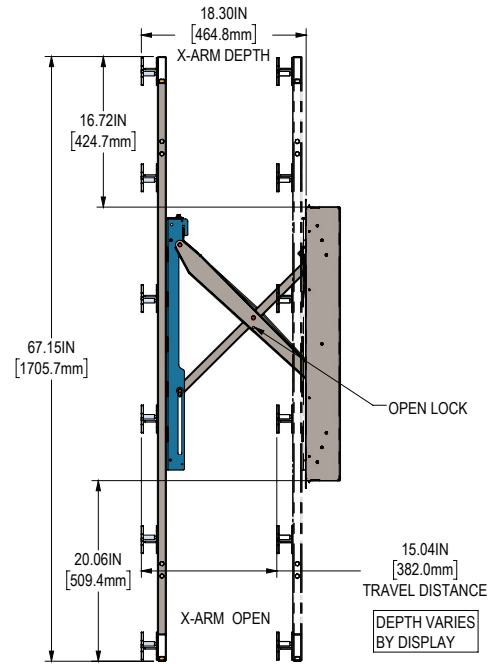

VIEW BELOW IS BACKBOX WITH X-ARMS ONLY - ADAPTER NOT SHOWN

TOP VIEW

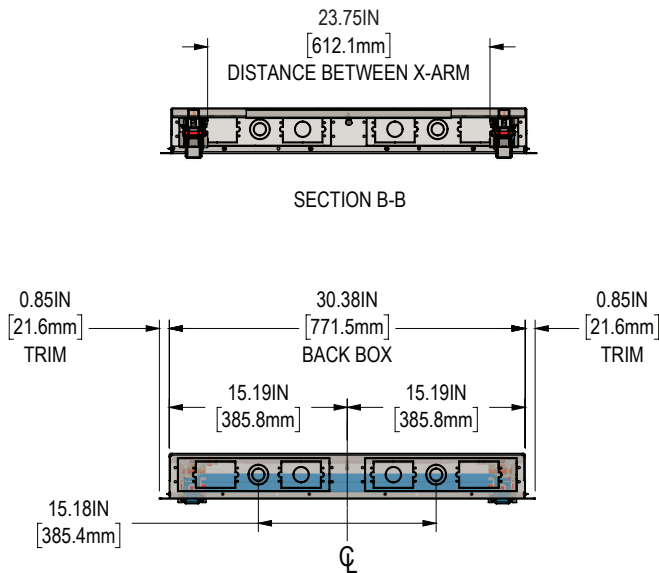

SIDE VIEW (X-ARMS CLOSE)

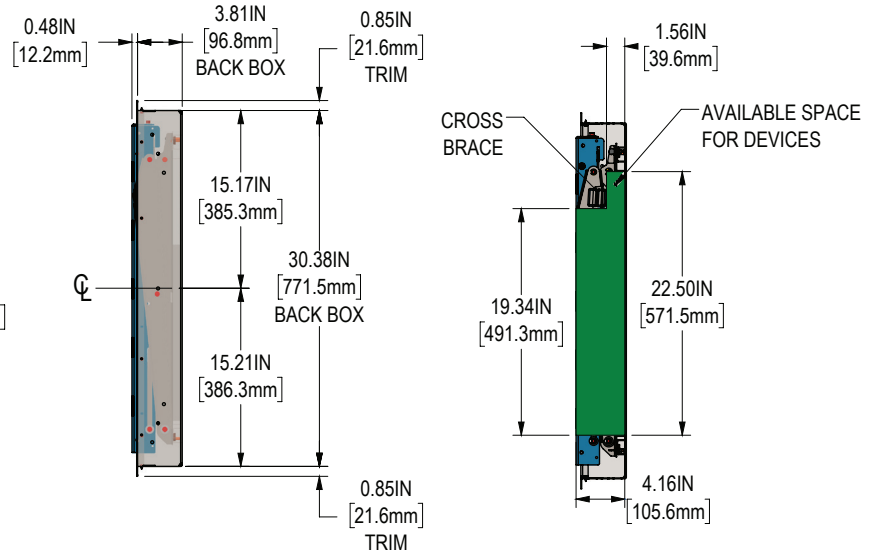

CONTACT US

rpvisuals.com/wallmate
info@rpvisuals.com
(714) 991-6400

- *2: Call for design assistance.
- *4 Changing from flat panels to LED systems requires a different mount interface. Call for design assistance.
- *5: LED system vary greatly for mounting requirements. Exact LED weight TBD based on mount interface requirements.
- *8: Estimated weight, weight varies by LED. Call for specific weights.
- *9: Depth may change by interface.
- *10: When 32MAX series back boxes are installed in 14 gauge studs, the weight limit is limited to 350 lbs.

