

This drawing contains proprietary information owned or controlled by RPVisual Solutions and must not be used or disclosed without prior written authorization

DIMENSIONS ARE IN INCHES  
TOLERANCES ARE:  
FRACTIONS DECIMALS ANGLES  
X/X : ± 1/32 .XX : ± .03 .X : ± .5  
.XXX : ± .010 .XX : ± .20

APPROVED FOR FABRICATION

SIGNATURE:

DATE:

NOTES:  
1. FINISH: SEMI-GLOSS BLACK POWDER COAT  
2. APPROXIMATE WEIGHT: 17

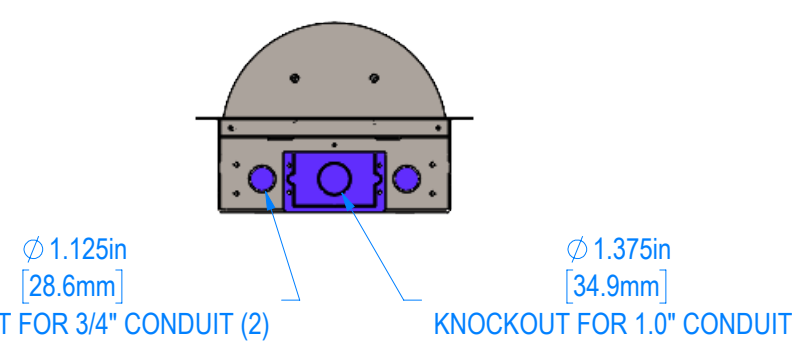
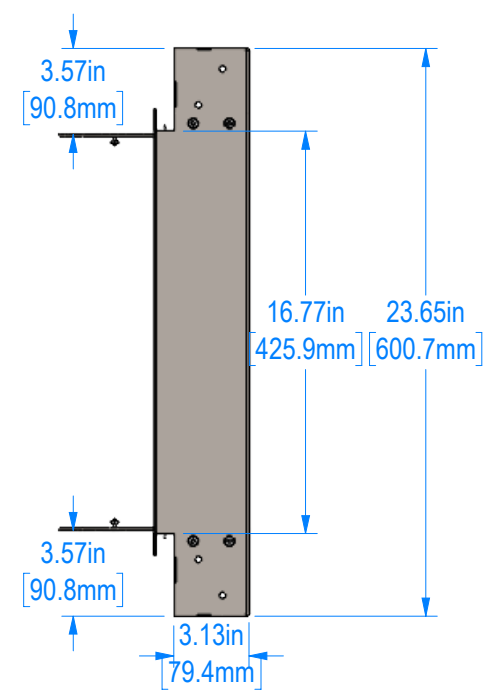
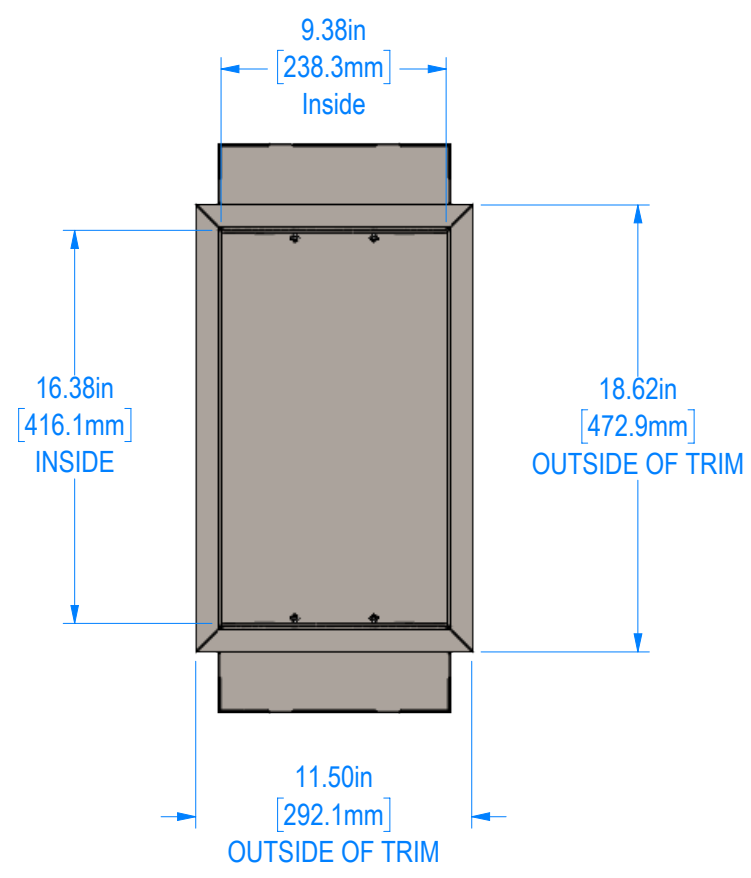
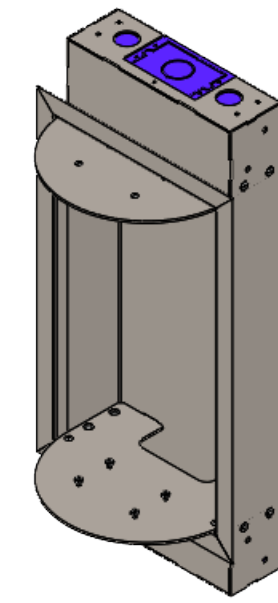
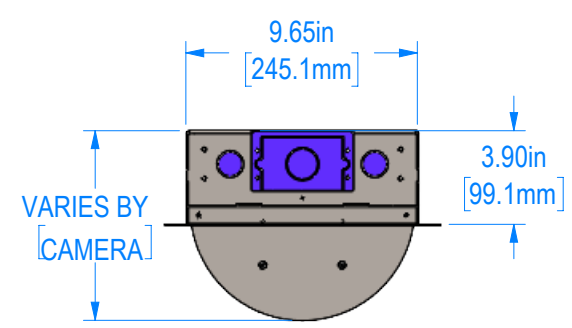

G	.	.	.
F	.	.	.
E	.	.	.
C	.	.	.
B	.	.	.
A	.	.	.
REV:	DESCRIPTION:	BY:	DATE:

DEALER:

PROJECT:

SKU: RPWM-C-CU2

PART NO: 19050

DESCRIPTION: Dual Camera Box

SIZE: B DATE: 8/23/2024 DRAWN: SV CHECKED: XX

DWG. ID: X.1

JOB NO: SCALE: 1:8 REVISION: SHEET: 1 OF 2

This drawing contains proprietary information owned or controlled by RPVisual Solutions and must not be used or disclosed without prior written authorization

*DIMENSIONS ARE IN INCHES*

*TOLERANCES ARE:*

FRACTIONS	DECIMALS	ANGLES
X/X : ± 1/32	.XX : ± .03 .XXX : ± .010	X : ± .5 .XX : ± .20

**APPROVED FOR FABRICATION**

SIGNATURE:

DATE:

NOTES:

1. FINISH: SEMI-GLOSS BLACK POWDER COAT
2. APPROXIMATE WEIGHT: 17

G			
F			
E			
C			
B			
A			

REV: DESCRIPTION: BY: DATE:

DEALER:

PROJECT:

SKU: RPWM-C-CU2

PART NO: 19050

DESCRIPTION: Dual Camera Box

SIZE: B	DATE: 8/23/2024	DRAWN: SV	CHECKED: XX
---------	-----------------	-----------	-------------

DWG. ID: X.2

JOB NO:	SCALE: 1:4	REVISION:
	SHEET: 2 OF 2	

